

(1)  
For an emulation of the classic chorus effect, as found in a vintage 2U rackmount box with pushbuttons for 4 preset modes, neither Option A nor Option B is needed. You need the "Subtle Chorus Main Board" in combination with this BBD board for this, however.

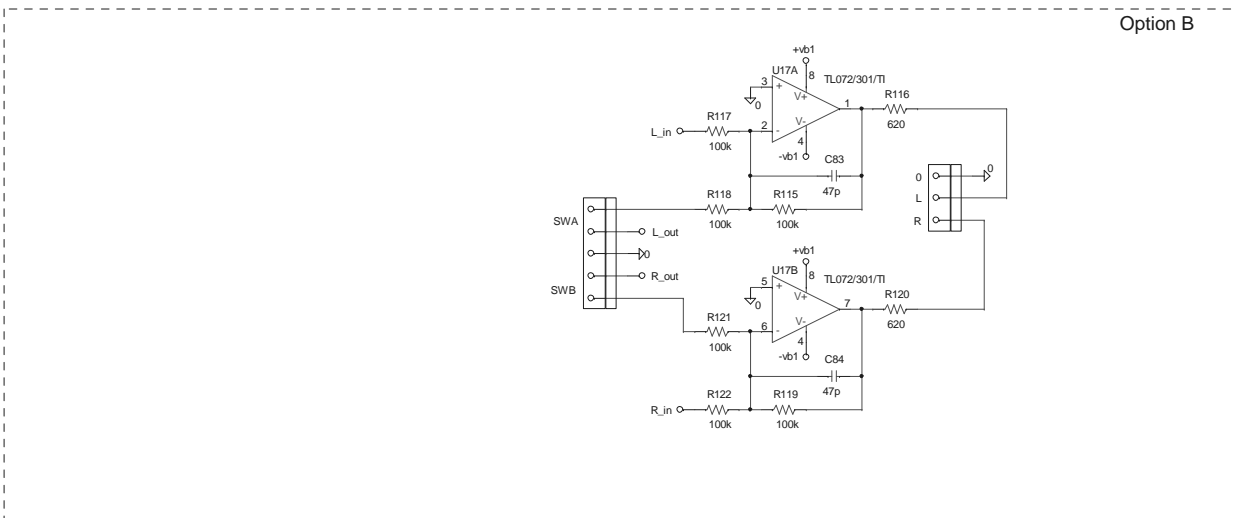

(2)  
For a standalone Stereo Chorus effect, only using the BBD board, you need both Option A (on-board LFO with VC Rate and VC Depth) and Option B (simple wet - dry signal summing stage).

(3)  
If you're building a device like (1), with the "Subtle Chorus Main Board" you can use Option A to add a second LFO with arbitrary Rate and Depth in addition to the preset LFO settings provided by the Main Board, going somewhat beyond the possibilities of the classic vintage effect.